

KOMATSU®

PW160-7

NET HORSEPOWER
90 kW 121 HP @ 2.200 rpm

OPERATING WEIGHT
15.470 - 17.090 kg

BUCKET CAPACITY
max. 1,0 m³

PW
160

HYDRAULIC WHEELED EXCAVATOR



PW160-7

WALK-AROUND

The PW160-7 is a rugged, productive, all-European machine. Designed and expressly built for European markets, it delivers productivity, reliability and operator comforts in a robust, environmentally-friendly package. Komatsu's exclusive, on-board, HydraMind system assists in all operations, providing enhanced machine performance that's always perfectly matched to the task.

What's new on Dash 7:

- High lifting capacity
- Low fuel consumption
- Easier maintenance and serviceability
- Improved operator comfort
- Lower noise
- Meets EC Stage II emission regulations
- Advanced Attachment Control
- Multi-function colour monitor
- PW160-7 has a standard width of 2,55 m

Advanced Attachment Control

The PW160-7 can be optionally equipped to handle a wide variety of attachments. The advanced attachment control system features:

- Operator selectable hydraulic flow control
- Adjustable presets for rapid attachment changeover
- Attachment piping options for breaker, clamshell or crusher

Undercarriage

- Designed for high ground clearance
- High oscillation angle
- Virtually zero axle rocking with outboard wet disc system
- Powerful drawbar pull
- Automatic 3-speed travel
- Class leading 35 km/h maximum travel speed

High productivity

- The powerful turbocharged and air-to-air aftercooled Komatsu SAA4D102E-2 provides 90 kW/121 HP.
- High lifting capacity and good stability



Excellent reliability and durability

- Reliable major components designed and built by Komatsu
- Exceptionally-reliable electronic devices

NET HORSEPOWER
90 kW 121 HP

OPERATING WEIGHT
15.470 - 17.090 kg

BUCKET CAPACITY
max. 1,0 m³

SpaceCab™

The new PW160-7's cabin space has been increased by 14%, offering an exceptionally-roomy operating environment.

- Sealed and pressurised cab with standard climate control
- Low-noise design
- Low-vibration design with cabin damper mounting
- Cab moved forward for better visibility
- Ergonomic control levers
- Seat specially designed for wheeled machines, with exceptional extra comfort

In harmony with the environment

- The low emission engine meets EC Stage II emissions standards with increased power and machine productivity
- The economy mode reduces fuel consumption
- Low operating noise
- Designed for easy end-of-life recycling



Easy maintenance

- One of the features now on the new wheeled excavator is a walkway across the excavator superstructure, giving easy access to the engine compartment.

EMMS

EMMS (Equipment Management and Monitoring System)

The EMMS is a highly sophisticated system, controlling and monitoring all the excavator functions. The user interface is highly intuitive and provides the operator with easy access to a huge range of functions and operating information.

Four working modes

The PW160-7 is equipped with three working modes: (A, E, B), plus a lifting mode (L). Each mode is designed to match the engine speed, pump speed, and system pressure with the current operating requirement. This provides the flexibility to match equipment performance to the job at hand.

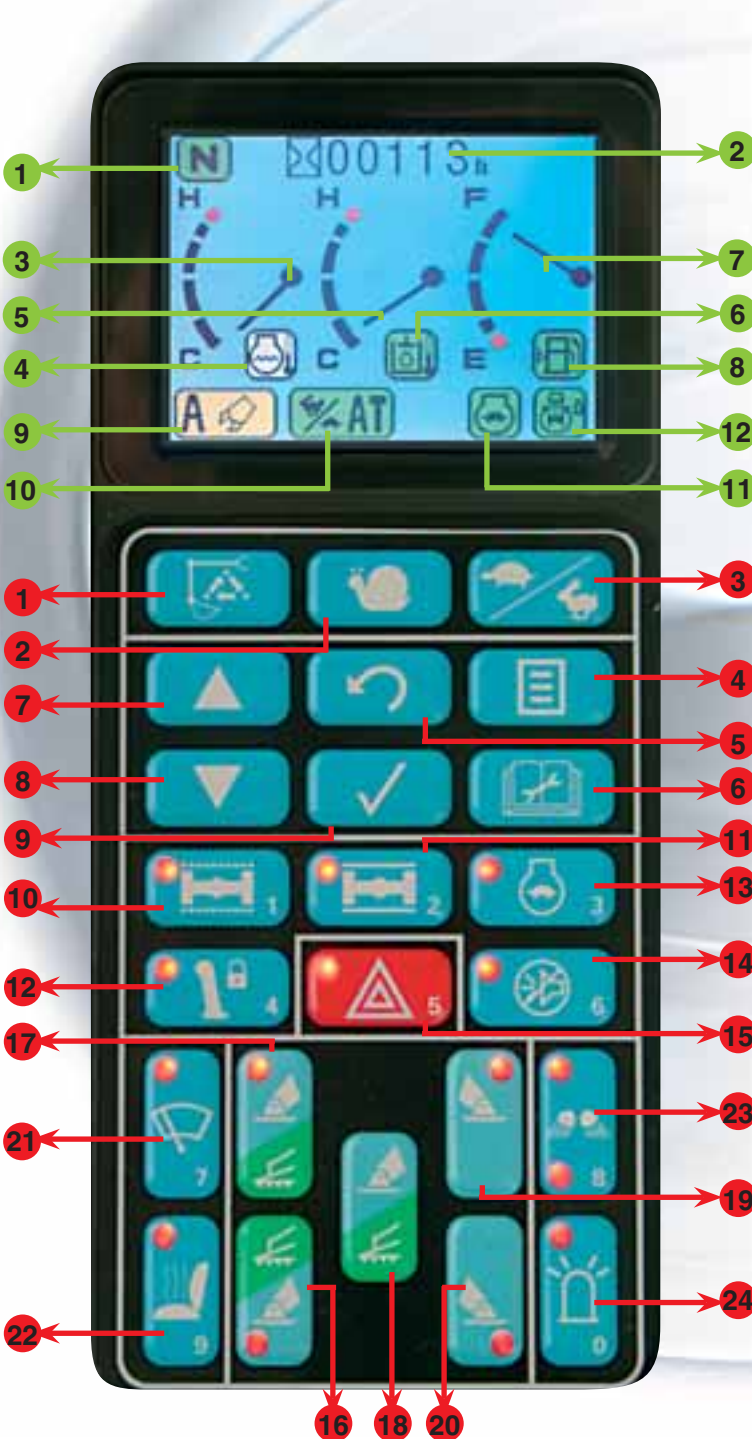

On-screen symbols

- 1 Travel direction
- 2 Service meter and clock
- 3 Engine water gauge
- 4 Engine water temperature warning
- 5 Hydraulic oil gauge
- 6 Hydraulic oil temperature warning
- 7 Fuel gauge
- 8 Fuel low level warning
- 9 Working mode
- 10 Travel mode
- 11 Auto deceleration
- 12 Swing lock

Push-button control switches

- 1 Working mode select
- 2 Creep speed
- 3 High/low speed select
- 4 Menu select key
- 5 Undo switch
- 6 Service menu
- 7 Scroll up
- 8 Scroll down
- 9 Accept key
- 10 Suspension auto lock
- 11 Suspension lock
- 12 Control lever lock
- 13 Engine auto deceleration
- 14 Buzzer cancel
- 15 Hazard warning
- 16 Rear left outrigger/blade
- 17 Front left outrigger/blade
- 18 Select all chassis attachment
- 19 Front right outrigger
- 20 Rear right outrigger
- 21 Lower wiper
- 22 Heated seat
- 23 Front and rear work lights
- 24 Beacon warning light

Active mode

For maximum power and fast cycle times. Normally used for heavy operations such as hard digging and loading. This mode allows access to the 'PowerMax' function to temporarily increase the digging force by 7% for added power in tough situations.

Economy mode

The environmentally-friendly mode. For running more quietly during operations at night and/or in urban areas. Fuel consumption and exhaust emissions are reduced.

Breaker mode

Delivers optimal hydraulic pressure, flow and engine RPMs for powerful breaker operations.

Lifting mode

Increases the lifting capacity 7% by raising the hydraulic pressure. This mode supports safe lifting operations.

Working mode	Application	Advantage
A	Active mode	<ul style="list-style-type: none"> • Maximum production/power • Fast cycle times
E	Economy mode	<ul style="list-style-type: none"> • Excellent fuel economy
B	Breaker mode	<ul style="list-style-type: none"> • Optimum engine RPMs and hydraulic flow
L	Lifting mode	<ul style="list-style-type: none"> • Hydraulic pressure has been increased by 7%



Hydraulic flow general adjustment screen in B (breaker) mode



Fine tune hydraulic flow adjustment screen in B (breaker) mode



Fine tune hydraulic flow adjustment screen in A (active) or E (economy) mode



Password screen

Easy to see and easy to use

Superb recognition colour LCD screens for each mode. Letters and numbers are combined with colour images for exceptionally clear and easy-to-read information. The high-resolution screen is easy to read in bright sunlight and in all lighting conditions.

Automatic three-speed travel

The travel speed is automatically shifted from high to low speed, according to the ground conditions.

	High	Low	Auto	Creep
Travel speed	35 km/h	9,5 km/h	0 - 35 km/h	2,0 km/h

Fingertip hydraulic pump oil flow adjustment

From the LCD monitor, you can automatically select the optimal hydraulic pump oil flow for breaking, crushing, and other operations in the B, A or E modes. Also, when simultaneously operating with attachments and work equipment, the flow to the attachment is reduced automatically, thus delivering a smooth movement of the work equipment.

Password protection

Prevents unauthorised machine use or transport. The engine cannot be started without your four-digit use or password.

For total security, the battery is connected directly to the starter motor. Both the starter and the engine need the password.

The password can be activated and deactivated upon request.

WORKING ENVIRONMENT

PW160-7's cab interior is spacious and provides a comfortable working environment...

SpaceCab™

Comfortable cab

The new PW160-7 inner cab volume is 14% greater than the Dash 6 models, offering an exceptionally comfortable operating environment. The large cab enables the seat, with headrest, to be reclined to horizontal.

Pressurised cab

The standard-equipped climate control, air filter and a higher internal air pressure resist dust entry into the cab.

Low-noise design

Noise levels are substantially reduced; engine noise as well as swing and hydraulics operations noise.

Cab damper mounting for low vibration levels

PW160-7 uses a new and improved viscous damping cab mount system that incorporates a longer stroke plus an added spring. The new cab damper mounting, combined with strengthened left and right-side decks, aids the reduction of vibrations to the operator's seat.

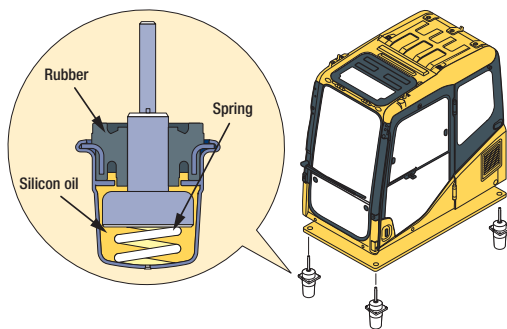

Outer air filter

Easy removal/installation of the air conditioner filter element, without tools facilitates easier cleaning.



Large sun roof with integrated sun shade



12-Volt power supply and (optional) radio cassette



Climate control



Tiltable steering wheel with several functions; wiper control, indicator, horn, and head lights

Safety features

Multi-position controls

The multi-position, proportional pressure control levers allow the operator to work in comfort whilst maintaining precise control. A double-slide mechanism allows the seat and controllers to move together, or independently, allowing the operator to position the controllers for maximum productivity and comfort.



Hot and cool box



Ergonomic 3 button lever



Seat sliding range: 340 mm – increased by 120 mm over the Dash 6



Defroster/demister

Improved, wide visibility

The right side window pillar has been removed and the rear pillar reshaped to provide greater visibility. Blind spots have been decreased by 34%.

Pump/engine room partition

This prevents hydraulic oil from spraying onto the engine to reduce the risk of fire.

Thermal and fan guards

Are placed around high-temperature parts of the engine. The fan belt and pulleys are well protected.

Steps with non-skid surface and large handrail

Steps with non-slip surfacing ensure safer maintenance.

Thermal guard



Non-slip sheet



Large handrail for safe access



FLEXIBILITY

ARMS

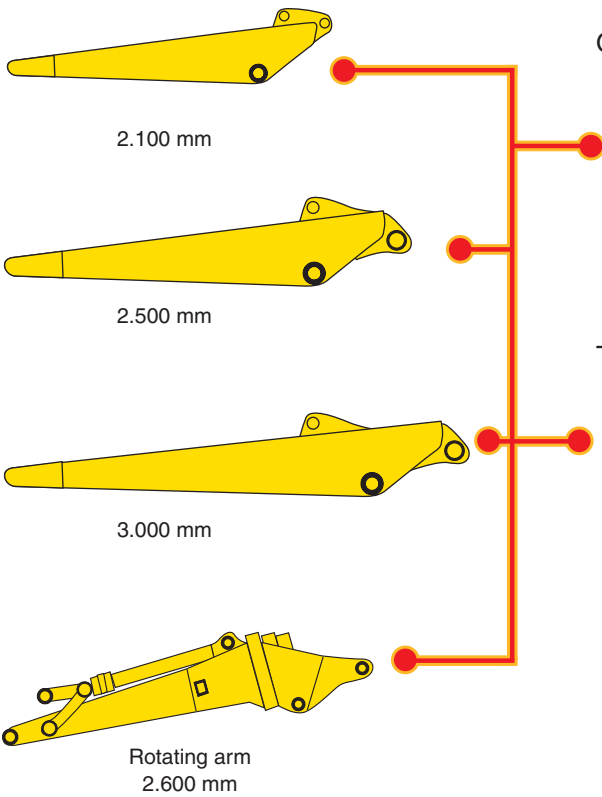

BOOMS

One piece boom

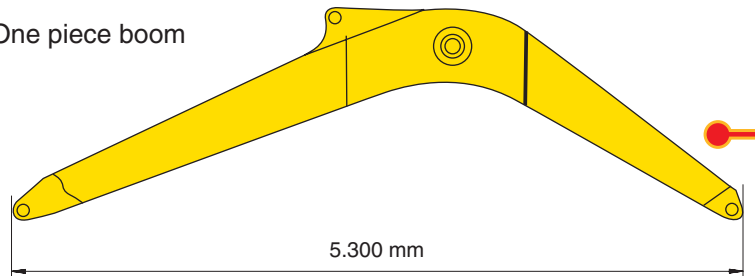

Two piece boom

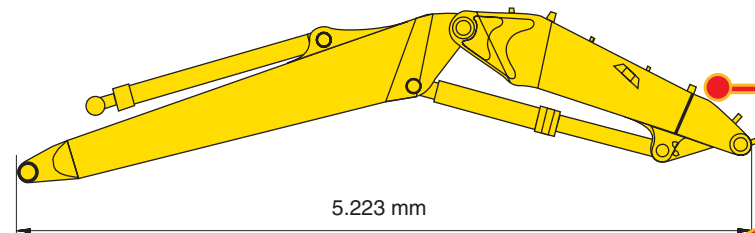

Parallel blade



Outriggers

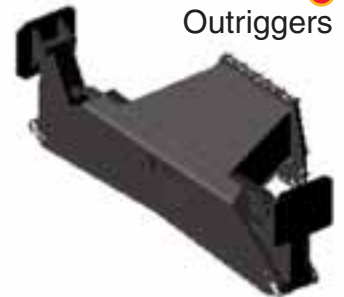

Additional hydraulic circuits

A 2-way additional hydraulic circuit, electrically controlled from the wrist control levers, is fitted as standard.



Outriggers

Independently controlled outriggers are optionally available on both, the front and rear of the machine. The cylinder protections are standard on the outriggers.

The PW160-7 can be specified with an enormous range of work equipment and undercarriage attachments to meet the needs of almost any application.



Parallel blade



Outriggers



Attachments commonality & functionality

The stabilizer and dozer blade are interchangeable, and therefore can be attached on the front or rear of the chassis. The stabilizer and dozer blade are controllable from the monitor panel. The monitor panel has five buttons that allow individual attachment operation as well as collective operation.



Toolbox
Tough, secure toolbox, integrated in the mudguards. Optionally fitted on both sides of the undercarriage.



Dozer blade
A parallel blade is available with standard cylinders protector for both the front and rear of the machine.

EASY OPERATION

As well as operating the standard work equipment movements, the RH wrist control lever is also used to operate the undercarriage. When used in conjunction with the selection switch on the control panel, full independent control of outriggers and dozer blade is immediately available. This feature, together with the automatic axle lock, enables the machine to be moved, stabilized and operated extremely quickly.

Clamshell/ breaker control

Clockwise clamshell rotation. Also used for breaker operation when B.O. mode is selected.

Clamshell control

Anti-clock wise clamshell rotation.



Undercarriage attachment control

After a single touch, the lever can be used to precisely operate the selected undercarriage attachment. After operating the undercarriage attachments, a single touch reverts the lever into standard boom operation.

Travel control

A rock button is installed on the right hand lever, it controls the travel operation into forward, neutral and rear. From the consistent weighting of the steering to the predictable and precise operation of the travel and brake pedals, the operator will always feel in complete control during traveling.



Travel pedal

PRODUCTIVITY FEATURES

High production levels and low fuel consumption

The increased output and fuel savings of the Komatsu SAA4D102E-2 engine result in increased productivity (tonnes per litre of fuel).



Engine

The PW160-7 gets its exceptional power and work capacity from a Komatsu SAA4D102E-2 engine. Its output is 90 kW/121 HP, providing increased hydraulic power and improved fuel efficiency.

Safe and precise lifting

PW160-7's stability is one of the best in his class. The machine is equipped with boom safety valves and overload caution as standard. This combined with the control of HydraulMind and the power of the lifting mode, gives incredible safe and precise lifting performance. Example: The over-front lifting capacity (reach 4,5 m over front, height 1,5 m) has a capacity of 9 tonnes (dozer blade down).

PowerMax function

PowerMax can be selected by depressing a joystick button for an instant burst of power to help break through tough digging situations. The PowerMax function is available in the A and E working mode.

Bucket digging force*: 10.400 kg

Arm crowd force*: 7.740 kg

* Measured with PowerMax function, 2.100 mm arm and ISO rating



VHMS

VHMS (Vehicle Health Monitoring System)

The VHMS's precise health-check system indicates all of the machine's running conditions. At the beginning of, and during, each work shift, abnormality information and machine functions can be checked from the operator's seat.

New features: VHMS machine health monitoring

- Up to four different mechanical system measurements can be monitored at the same time.
- A "Maintenance Indicator" function has been added. (Filter and oil replacement time display function).
- Mechanical system failures are now monitored, in addition to electrical system failures.
- Failures are indicated with a 6-digit failure code.

Displays running conditions and abnormality indications

At the operator's fingertips: the VHMS controller monitors engine oil level, cooling water level, fuel level, engine water temperature, engine oil pressure, battery charging level, air filter clogging, and more.

The monitor also indicates whenever abnormalities are detected.

Maintenance alert assistance

The VHMS monitor alerts when oil and filters need to be replaced.

Operation data memory

The system memorises machine operating data such as engine output, hydraulic pressure, and more.

Trouble data memory

The monitor stores and recalls electrical system and mechanical system failures and abnormalities for effective troubleshooting. The twenty most-recent electrical system failures are stored. Mechanical system failures cannot be erased, ensuring accurate documentation of vital service management information.

VHMS 'real time monitoring system'

The 'real time monitoring system' displays up to four different operating parameters simultaneously, giving the mechanic a total overview for faster troubleshooting. Parameters include operating conditions such as hydraulic oil pressure, engine RPMs, various voltages and currents, and even temperature measurement.



Real time monitoring

Reducing maintenance costs

Extended replacement intervals for engine oil and filters

New, high-performance filters are used in the hydraulic circuit and engine. Replacement intervals for the hydraulic oil filter have been significantly extended, reducing maintenance costs.

Replacement intervals	PW160-7
Engine oil	500 h
Engine oil filter	500 h
Hydraulic oil	5.000 h
Hydraulic oil filter	1.000 h



Designed and built for strength

Using the latest computer aided design techniques and exhaustive testing, the boom and arm designs have been optimised for strength and durability. The boom top and bottom plates are manufactured from single plates, again to distribute loads evenly and avoid potential weak points.

The highly automated manufacturing process uses the very latest equipment and quality control techniques. Critical welding is carried out by robots to ensure an extremely high quality and consistent product.

Precision engineered pin and bush system. The key work equipment joints use a chrome plated pin and bronze bushing system to provide minimal play and extended durability.

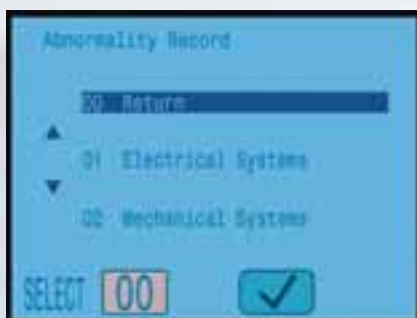

Trouble data memory



Maintenance record



Maintenance mode change

SPECIFICATIONS



ENGINE

Model Komatsu SAA4D102E-2
 Type Direct injection, water-cooled, emissionised, turbocharged, after-cooled diesel
 Rated capacity 90 kW/121 HP (ISO 9249 Net) at engine speed 2.200 rpm
 No. of cylinders 4
 Bore x stroke 102 x 120 mm
 Displacement 3,9 ltr
 Battery 2 x 12 V/40 Ah
 Alternator 24 V/95 A
 Starter motor 24 V/4,5 kW
 Air filter type Double element type with monitor panel dust indicator and auto dust evacuator
 Cooling Suction type cooling fan



HYDRAULIC SYSTEM

Type HydraMind. Closed-centre system with load sensing and pressure compensation valves
 Additional circuits Depending on the specification up to 2 additional circuits can be installed
 Main pump variable displacement piston pump supplying boom, arm, bucket, swing and travel circuits
 Maximum pump flow 308 ltr/min
 Relief valve settings
 Implement 380 kg/cm²
 Travel 420 kg/cm²
 Swing 295 kg/cm²
 Pilot circuit 36 kg/cm²



ENVIRONMENT

Engine emissions Fully complies with EC Stage II exhaust emission regulations
 Noise levels
 LwA external 101 dB(A) (2000/14/EC)
 LpA operator ear 71 dB(A) (ISO 6369 dynamic test)



OPERATING WEIGHT (APPR.)

Operating weight, including 5.300 mm one-piece boom, or 5.223 mm two piece boom, 2.500 mm arm, operator, lubricant, coolant, full fuel tank and the standard equipment. Weights are with 495 kg bucket.

Undercarriage type	Operating weight mono boom	Operating weight two-piece boom
Rear blade	15.470 kg	15.860 kg
Rear outrigger	15.700 kg	16.090 kg
2 outriggers + blade	16.470 kg	16.860 kg
4 outriggers	16.700 kg	17.090 kg



SWING SYSTEM

Type Axial piston motor driving through planetary double reduction gearbox.
 Swing lock Electrically actuated wet multi-disc brake integrated into swing motor. An additional mechanical pin can be engaged from inside the operator cab.
 Swing speed 0 - 11,5 rpm



TRANSMISSION

Type Fully automatic power shift transmission with permanent 4 wheel drive
 Travel motors one variable displacement axial piston motor
 Maximum pressure 380 kg/cm²
 Travel modes 3 travel modes:
 Max. travel speeds
 Hi / Lo / Creep 35 / 10 / 2,0 km/h
 A max. speed restriction of 20 km/h is available as an option.
 Maximum drawbar pull 9.750 kg
 Front axle load lower than 6.100 kg
 Rear axle load lower than 9.800 kg
 Axle oscillation 10° Lockable in any position from the operator cab.



BRAKE SYSTEM

Type Dual circuit hydraulic braking system supplied from a separate gear pump.
 Service brakes Pedal actuated wet multi-disc brakes integrated into the axle hubs.
 Parking brake Electrically actuated wet multi-disc "spring actuation hydraulic release" brake integrated into the transmission.



STEERING SYSTEM

Steering control Hydraulic steering system supplied from a separate gear pump and controlled through LS orbitrol & priority valves.
 Minimum turning radius for 2,5 m wide axles 6.790 mm (to center of outer wheel)



COOLANT AND LUBRICANT CAPACITY (REFILLING)

Fuel tank 290 ltr
 Radiator 14,5 ltr
 Engine oil 16 ltr
 Swing drive 4,5 ltr
 Hydraulic tank 166 ltr
 Transmission 4,85 ltr
 Front differential 10,5 ltr
 Rear differential 9,5 ltr
 Front axle hub 2,5 ltr
 Rear axle hub 2,0 ltr
 Swing pinion grease bath amount 9,0 ltr

BUCKET OPTIONS & DIGGING FORCES

Specifications and equipment may vary according to regional availability

PW160-7

BUCKET AND ARM COMBINATIONS					
Width	Bucket		Arm length		
	Capacity (SAE)	Weight	2.100 mm	2.500 mm	3.000 mm
400 mm	0,20 m ³	270 kg	○	○	○
450 mm	0,27 m ³	300 kg	○	○	○
600 mm	0,41 m ³	420 kg	○	○	○
700 mm	0,48 m ³	445 kg	○	○	○
800 mm	0,55 m ³	460 kg	○	○	○
900 mm	0,62 m ³	495 kg	○	○	○
1.000 mm	0,69 m ³	530 kg	○	○	○
1.100 mm	0,76 m ³	550 kg	○	□	□
1.200 mm	0,83 m ³	575 kg	□	□	□
1.300 mm	0,90 m ³	605 kg	□	△	△
1.400 mm	0,97 m ³	630 kg	△	△	△

Please consult with your distributor for the correct selection of buckets and attachments to suit the application. The recommendations are given as a guide only, based on typical operating conditions.

○ Material weight up to 1,8 t/m³
 □ Material weight up to 1,5 t/m³
 △ Material weight up to 1,2 t/m³
 – Not usable

BUCKET AND ARM FORCE			
Arm length	2.100 mm	2.500 mm	3.000 mm
Bucket digging force	9.700 kg	9.700 kg	9.700 kg
Bucket digging force at power max	10.400 kg	10.400 kg	10.400 kg
Arm crowd force	7.260 kg	6.100 kg	5.080 kg
Arm crowd force at power max	7.740 kg	6.500 kg	5.420 kg

DIMENSIONS

MONO BOOM

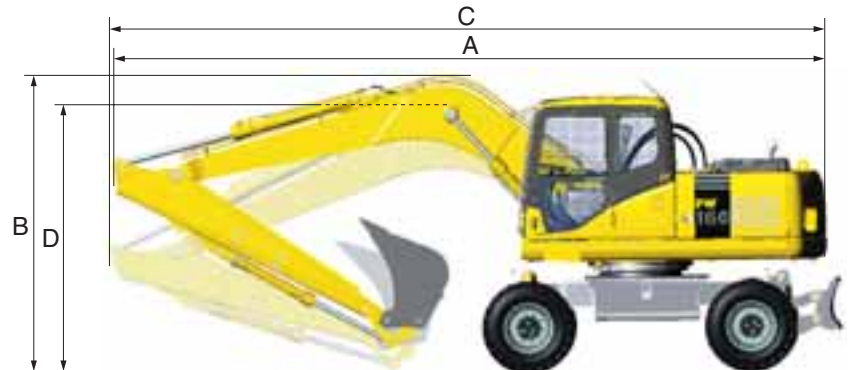

TWO-PIECE BOOM

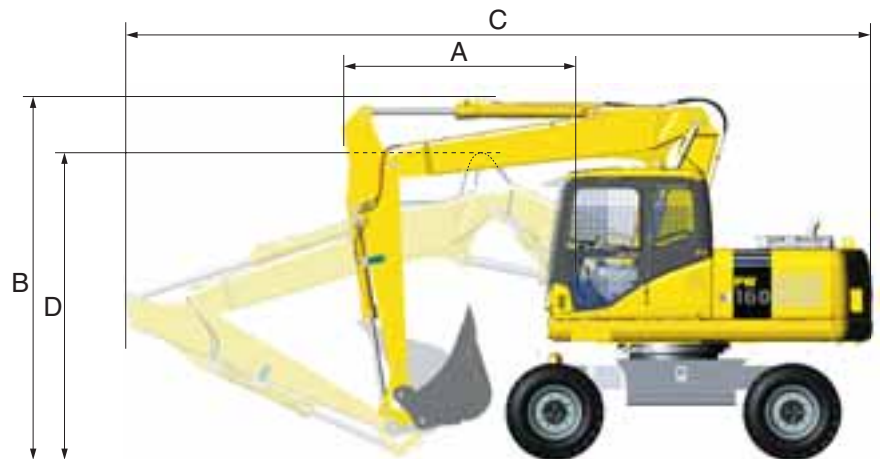
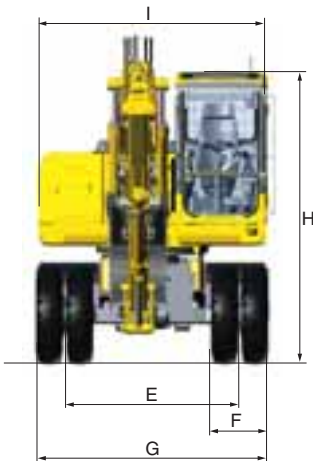

DIMENSIONS	
E	1.915
F	625
G	2.550
H	3.200
I	2.490

MONO BOOM				
Arm	Driving position		Transport position	
	A	B	C	D
2,1 m	8.290	3.500	8.330	3.185
2,5 m	8.290	3.500	8.345	3.235
3,0 m	8.045	3.975	8.365	3.415

TWO-PIECE BOOM				
Arm	Driving position		Transport position	
	A	B	C	D
2,1 m	2.575	3.975	8.225	3.240
2,5 m	2.595	3.975	8.200	3.350
3,0 m	2.665	3.975	8.120	3.565

DIMENSIONS & UNDERCARRIAGE

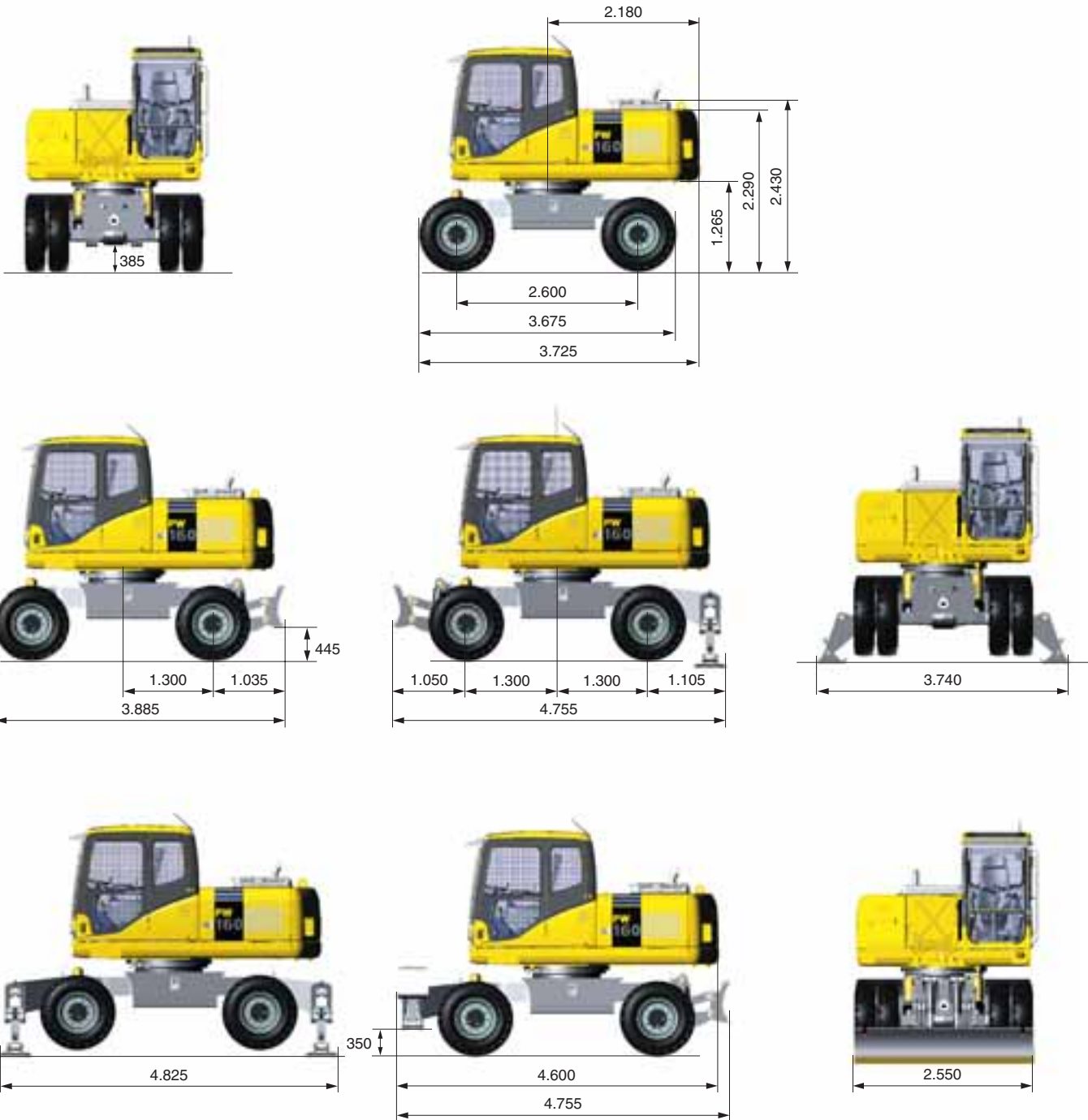

WORKING RANGES

MONO BOOM

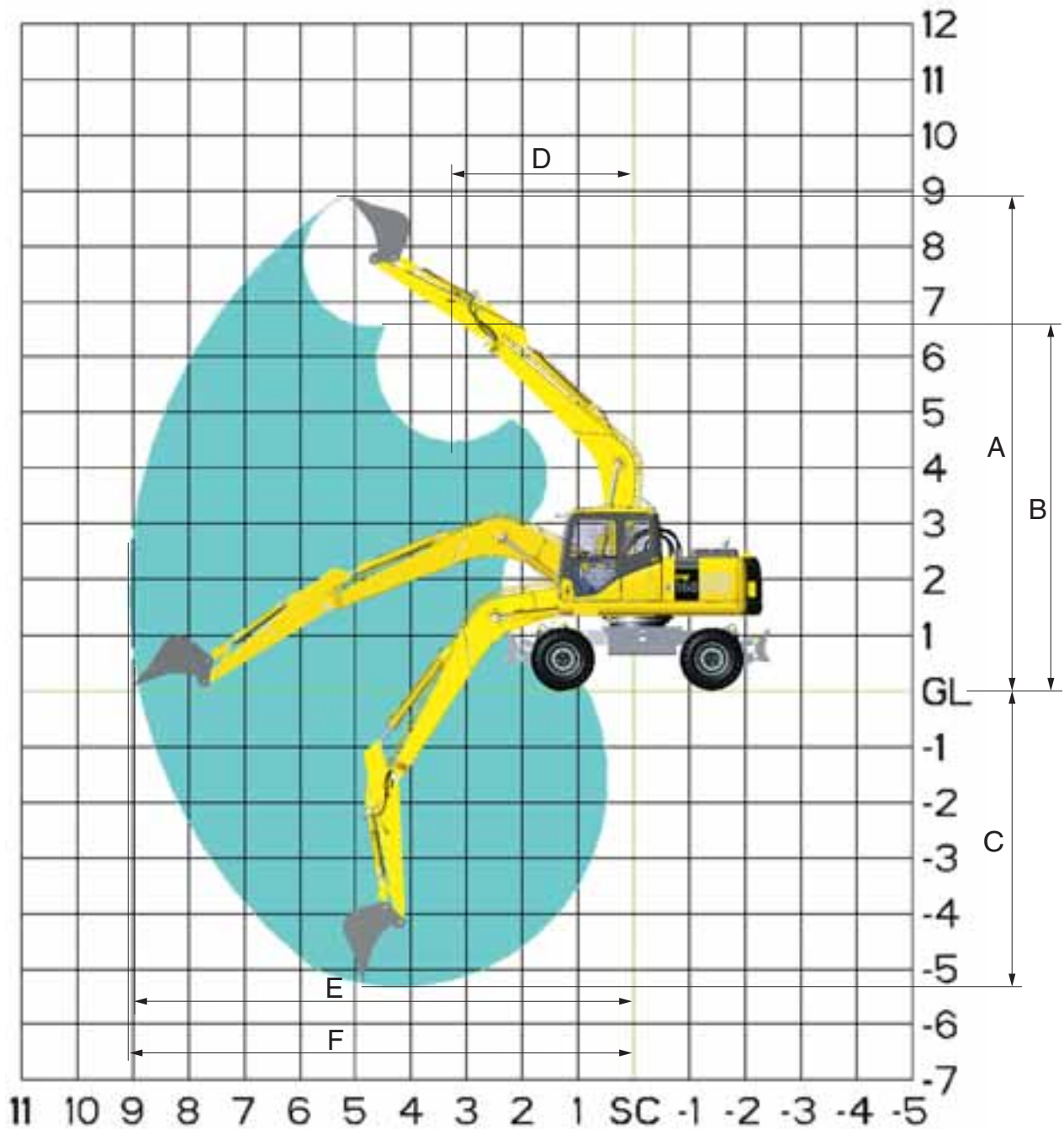

ARM LENGTH		2.100 mm	2.500 mm	3.000 mm
A	Max. digging height	8.730 mm	8.930 mm	9.285 mm
B	Max. dumping height	6.335 mm	6.555 mm	6.911 mm
C	Max. digging depth	5.080 mm	5.420 mm	5.895 mm
D	Min. swing radius	3.205 mm	3.160 mm	3.180 mm
E	Max. digging reach at ground level	8.620 mm	8.895 mm	9.505 mm
F	Max. digging reach	8.740 mm	9.070 mm	9.615 mm

TWO-PIECE BOOM

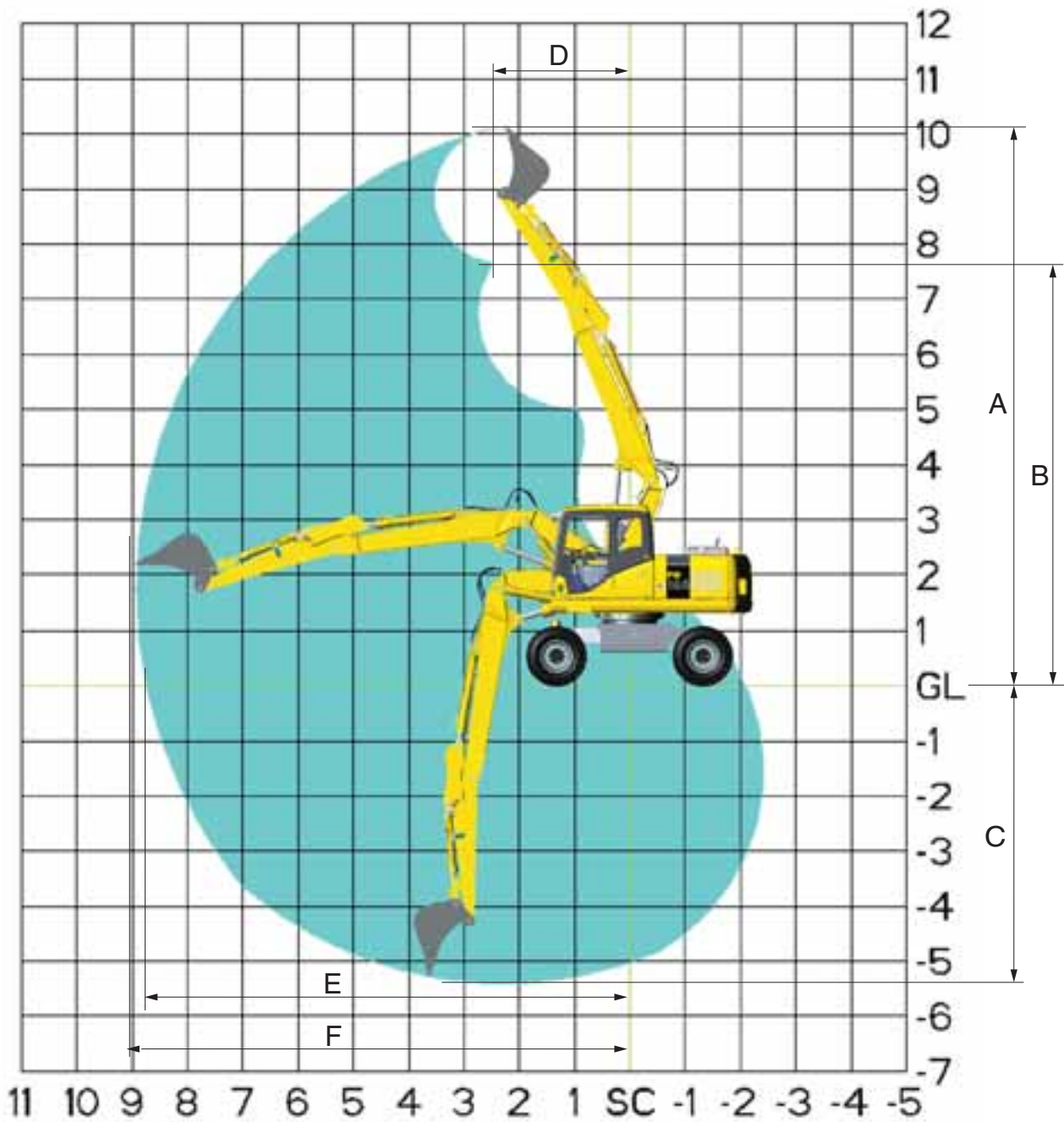

ARM LENGTH		2.100 mm	2.500 mm	3.000 mm
A	Max. digging height	9.745 mm	10.118 mm	10.575 mm
B	Max. dumping height	7.285 mm	7.655 mm	8.117 mm
C	Max. digging depth	5.160 mm	5.600 mm	6.100 mm
D	Min. swing radius	2.215 mm	2.385 mm	2.590 mm
E	Max. digging reach at ground level	8.510 mm	8.900 mm	9.410 mm
F	Max. digging reach	8.705 mm	9.019 mm	9.560 mm

LIFTING CAPACITY

PW160-7 MONO BOOM

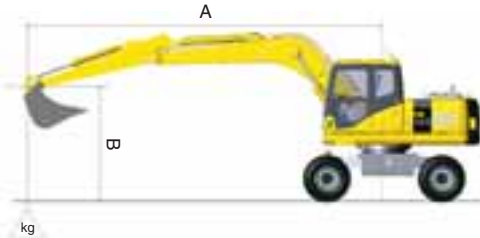

- A – Reach from swing center
- B – Bucket hook height
- C – Lifting capacities, including bucket (495 kg), bucket linkage (90 kg) and bucket cylinder (125 kg)

When removing bucket, linkage or cylinder, lifting capacities can be increased by their respective weights.

- Rating over front
- Rating over side
- Rating at maximum reach

Arm length	A	B			7,5 m		6,0 m		4,5 m		3,0 m	

Without stabilizer	Arm length	A	B			7,5 m		6,0 m		4,5 m		3,0 m	
	2,1 m	7,5 m	kg	*2.450	*2.450								
		6,0 m	kg	*2.100	*1.800			3.150	2.200				
	4,5 m	kg	*1.950	1.450			3.100	2.150	5.050	3.500			
	3,0 m	kg	1.900	1.250	2.050	1.350	2.950	2.050	4.700	3.200			
	1,5 m	kg	1.850	1.200	2.000	1.300	2.850	1.900	4.350	2.900			
	0,0 m	kg	1.900	1.250	1.950	1.250	2.750	1.800	4.200	2.750			
	-1,5 m	kg	2.100	1.400			2.700	1.750	4.150	2.700	*6.900	5.000	
	-3,0 m	kg	2.700	1.800			2.750	1.850	4.200	2.750	*6.550	5.150	
	2,5 m	7,5 m	kg	*1.800	*1.800								
		6,0 m	kg	*1.600	*1.600			3.150	2.200				
		4,5 m	kg	*1.550	1.350	*2.000	1.400	3.100	2.150				
		3,0 m	kg	*1.600	1.150	2.050	1.350	3.000	2.050	4.750	3.250	9.500	6.050
1,5 m		kg	*1.700	1.100	1.950	1.300	2.850	1.900	4.450	2.950			
0,0 m		kg	1.750	1.150	1.900	1.250	2.750	1.800	4.250	2.750	*4.400	*4.400	
-1,5 m		kg	1.950	1.250			2.700	1.750	4.150	2.700	*7.100	5.050	
-3,0 m		kg	2.400	1.600			2.700	1.800	4.200	2.750	*7.550	5.150	
3,0 m		7,5 m	kg	*1.450	*1.450			*2.350	2.150				
		6,0 m	kg	*1.300	*1.300	*1.450	1.350	*2.900	2.200				
		4,5 m	kg	*1.200	1.100	2.050	1.350	3.100	2.150				
		3,0 m	kg	*1.200	950	2.000	1.300	2.950	2.000	4.800	3.300		
	1,5 m	kg	*1.300	900	1.900	1.250	2.800	1.850	4.400	2.900			
	0,0 m	kg	*1.450	900	1.850	1.200	2.650	1.750	4.150	2.700	*4.050	*4.050	
	-1,5 m	kg	1.650	1.000	1.800	1.150	2.600	1.650	4.050	2.600	*5.950	4.800	
	-3,0 m	kg	1.950	1.250			2.600	1.650	4.050	2.600	8.100	4.900	

Front/rear dozer blade	Arm length	A	B			7,5 m		6,0 m		4,5 m		3,0 m	
	2,1 m	7,5 m	kg	*2.450	*2.450								
		6,0 m	kg	*2.100	*2.100			*3.750	2.600				
	4,5 m	kg	*1.950	1.750			*4.700	2.550	*5.250	4.150			
	3,0 m	kg	*1.950	1.550	*3.350	1.650	*5.100	2.450	*6.700	3.800			
	1,5 m	kg	*2.050	1.500	4.000	1.600	*5.400	2.300	*7.500	3.500			
	0,0 m	kg	*2.300	1.500	*3.450	1.550	*5.400	2.200	*7.450	3.350			
	-1,5 m	kg	*2.750	1.700			*4.850	2.200	*6.650	3.300	*6.900	6.250	
	-3,0 m	kg	*2.900	2.200			*3.200	2.250	*5.050	3.350	*6.550	6.400	
	2,5 m	7,5 m	kg	*1.800	*1.800								
		6,0 m	kg	*1.600	*1.600			*3.200	2.600				
		4,5 m	kg	*1.550	*1.550	*2.000	1.700	*4.100	2.550				
		3,0 m	kg	*1.600	1.450	*3.300	1.650	*4.900	2.450	*6.400	3.900	*10.050	7.350
1,5 m		kg	*1.700	1.400	4.000	1.600	*5.300	2.300	*7.350	3.600			
0,0 m		kg	*1.950	1.400	3.950	1.550	*5.400	2.200	*7.550	3.400	*4.400	*4.400	
-1,5 m		kg	*2.400	1.600			*5.050	2.150	*6.950	3.300	*7.100	6.250	
-3,0 m		kg	*3.150	1.950			*3.850	2.200	*5.550	3.350	*7.550	6.400	
3,0 m		7,5 m	kg	*1.450	*1.450			*2.350	*2.350				
		6,0 m	kg	*1.300	*1.300	*1.450	*1.450	*2.900	2.650				
		4,5 m	kg	*1.200	*1.200	*2.700	1.650	*3.250	2.550				
		3,0 m	kg	*1.200	1.200	*3.350	1.600	*4.350	2.450	*5.450	3.900		
	1,5 m	kg	*1.300	1.150	3.950	1.550	*5.050	2.250	*6.900	3.500			
	0,0 m	kg	*1.450	1.200	3.850	1.500	*5.300	2.150	*7.400	3.300	*4.050	*4.050	
	-1,5 m	kg	*1.700	1.300	*3.700	1.450	*5.100	2.050	*7.100	3.200	*5.950	*5.950	
	-3,0 m	kg	*2.200	1.600			*4.250	2.050	*6.000	3.200	*8.550	6.150	

* Load is limited by hydraulic capacity rather than tipping.
 Ratings are based on SAE Standard No. J1097.
 Rated loads do not exceed 87% of hydraulic lift capacity or 75% of tipping load.

PW160-7 MONO BOOM

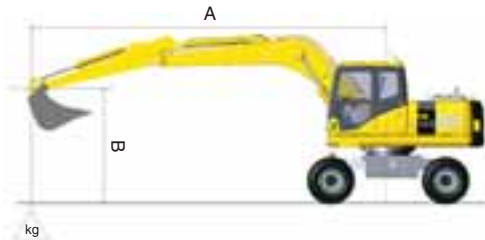

- A** – Reach from swing center
- B** – Bucket hook height
- C** – Lifting capacities, including bucket (495 kg), bucket linkage (90 kg) and bucket cylinder (125 kg)

When removing bucket, linkage or cylinder, lifting capacities can be increased by their respective weights.

- Rating over front
- Rating over side
- Rating at maximum reach

Arm length	A	B			7,5 m		6,0 m		4,5 m		3,0 m	

	2,1 m	7,5 m	kg	*2.450	*2.450								
		6,0 m	kg	*2.100	*2.100			*3.750	*3.750				
	4,5 m	kg	*1.950	*1.950			*4.700	3.800	*5.250	*5.250			
	3,0 m	kg	*1.950	*1.950	*3.350	2.550	*5.100	3.700	*6.700	5.800			
	1,5 m	kg	*2.050	*2.050	*4.150	2.500	*5.400	3.550	*7.500	5.500			
	0,0 m	kg	*2.300	*2.300	*3.450	2.450	*5.400	3.450	*7.450	5.300			
	-1,5 m	kg	*2.750	2.700			*4.850	3.400	*6.650	5.250	*6.900	*6.900	
	-3,0 m	kg	*2.900	*2.900			*3.200	*3.200	*5.050	*5.050	*6.550	*6.550	
	2,5 m	7,5 m	kg	*1.800	*1.800								
		6,0 m	kg	*1.600	*1.600			*3.200	*3.200				
		4,5 m	kg	*1.550	*1.550	*2.000	*2.000	*4.100	3.850				
		3,0 m	kg	*1.600	*1.600	*3.300	2.550	*4.900	3.700	*6.400	5.900	*10.050	*10.050
		1,5 m	kg	*1.700	*1.700	*4.150	2.500	*5.300	3.550	*7.350	5.550		
0,0 m		kg	*1.950	*1.950	*4.050	2.450	*5.400	3.450	*7.550	5.350	*4.400	*4.400	
-1,5 m		kg	*2.400	*2.400			*5.050	3.400	*6.950	5.250	*7.100	*7.100	
-3,0 m	kg	*3.150	3.050			*3.850	3.400	*5.550	5.300	*7.550	*7.550		
3,0 m	7,5 m	kg	*1.450	*1.450			*2.350	*2.350					
	6,0 m	kg	*1.300	*1.300	*1.450	*1.450	*2.900	*2.900					
	4,5 m	kg	*1.200	*1.200	*2.700	2.600	*3.250	*3.250					
	3,0 m	kg	*1.200	*1.200	*3.350	2.500	*4.350	3.700	*5.450	*5.450			
	1,5 m	kg	*1.300	*1.300	*4.050	2.450	*5.050	3.500	*6.900	5.500			
	0,0 m	kg	*1.450	*1.450	*4.050	2.350	*5.300	3.350	*7.400	5.250	*4.050	*4.050	
	-1,5 m	kg	*1.700	*1.700	*3.700	2.350	*5.100	3.300	*7.100	5.150	*5.950	*5.950	
	-3,0 m	kg	*2.200	*2.200			*4.250	3.300	*6.000	5.150	*8.550	*8.550	

	2,1 m	7,5 m	kg	*2.450	*2.450								
		6,0 m	kg	*2.100	*2.100			*3.750	*3.750				
	4,5 m	kg	*1.950	*1.950			*4.700	4.550	*5.250	*5.250			
	3,0 m	kg	*1.950	*1.950	*3.350	3.050	*5.100	4.400	*6.700	*6.700			
	1,5 m	kg	*2.050	*2.050	*4.150	3.000	*5.400	4.250	*7.500	6.700			
	0,0 m	kg	*2.300	*2.300	*3.450	2.950	*5.400	4.150	*7.450	6.500			
	-1,5 m	kg	*2.750	*2.750			*4.850	4.100	*6.650	6.450	*6.900	*6.900	
	-3,0 m	kg	*2.900	*2.900			*3.200	*3.200	*5.050	*5.050	*6.550	*6.550	
	2,5 m	7,5 m	kg	*1.800	*1.800								
		6,0 m	kg	*1.600	*1.600			*3.200	*3.200				
		4,5 m	kg	*1.550	*1.550	*2.000	*2.000	*4.100	*4.100				
		3,0 m	kg	*1.600	*1.600	*3.300	3.050	*4.900	4.400	*6.400	*6.400	*10.050	*10.050
		1,5 m	kg	*1.700	*1.700	*4.150	3.000	*5.300	4.250	*7.350	6.750		
0,0 m		kg	*1.950	*1.950	*4.050	2.950	*5.400	4.150	*7.550	6.550	*4.400	*4.400	
-1,5 m		kg	*2.400	*2.400			*5.050	4.100	*6.950	6.450	*7.100	*7.100	
-3,0 m	kg	*3.150	*3.150			*3.850	*3.850	*5.550	*5.550	*7.550	*7.550		
3,0 m	7,5 m	kg	*1.450	*1.450			*2.350	*2.350					
	6,0 m	kg	*1.300	*1.300	*1.450	*1.450	*2.900	*2.900					
	4,5 m	kg	*1.200	*1.200	*2.700	*2.700	*3.250	*3.250					
	3,0 m	kg	*1.200	*1.200	*3.350	3.050	*4.350	*4.350	*5.450	*5.450			
	1,5 m	kg	*1.300	*1.300	*4.050	2.950	*5.050	4.250	*6.900	6.700			
	0,0 m	kg	*1.450	*1.450	*4.050	2.850	*5.300	4.100	*7.400	6.450	*4.050	*4.050	
	-1,5 m	kg	*1.700	*1.700	*3.700	2.850	*5.100	4.000	*7.100	6.350	*5.950	*5.950	
	-3,0 m	kg	*2.200	*2.200			*4.250	4.000	*6.000	*6.000	*8.550	*8.550	

* Load is limited by hydraulic capacity rather than tipping.
 Ratings are based on SAE Standard No. J1097.
 Rated loads do not exceed 87% of hydraulic lift capacity or 75% of tipping load.

LIFTING CAPACITY

PW160-7 TWO-PIECE BOOM

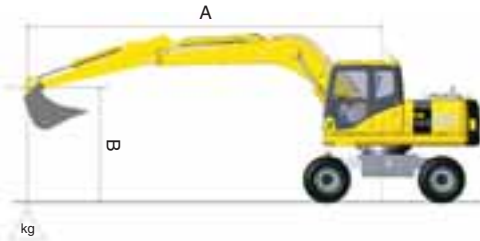

- A – Reach from swing center
- B – Bucket hook height
- C – Lifting capacities, including bucket (495 kg), bucket linkage (90 kg) and bucket cylinder (125 kg)

When removing bucket, linkage or cylinder, lifting capacities can be increased by their respective weights.

- Rating over front
- Rating over side
- Rating at maximum reach

Arm length	A			7,5 m		6,0 m		4,5 m		3,0 m	

	2,1 m	7,5 m	kg	*2.300	*2.300				*3.650	*3.650				
		6,0 m	kg	*1.900	*1.900			*3.050	2.050	*4.200	3.550			
		4,5 m	kg	*1.800	1.400			3.000	2.050	4.950	3.400	*5.000	*5.000	
		3,0 m	kg	*1.800	1.250	1.950	1.250	2.900	1.950	4.700	3.150			
		1,5 m	kg	1.850	1.150	1.900	1.200	2.800	1.850	4.400	2.900			
		0,0 m	kg	1.900	1.200			2.700	1.750	4.250	2.750			
		-1,5 m	kg	2.150	1.400			2.650	1.750	4.200	2.700	*7.400	5.100	
		-3,0 m	kg							4.250	2.750			
		2,5 m	7,5 m	kg	*1.750	*1.750				*3.350	*3.350			
			6,0 m	kg	*1.500	*1.500			3.050	2.100	*3.450	*3.450		
			4,5 m	kg	*1.400	1.200	*1.750	1.250	3.000	2.050	*4.000	3.450	*3.500	*3.500
			3,0 m	kg	*1.400	1.050	1.950	1.250	2.900	1.950	4.700	3.150		
			1,5 m	kg	*1.500	1.000	1.850	1.200	2.750	1.800	4.350	2.850		
		0,0 m	kg	*1.650	1.050	1.800	1.150	2.650	1.700	4.150	2.650	*4.050	*4.050	
		-1,5 m	kg	1.900	1.200			2.600	1.650	4.100	2.600	*6.900	4.950	
		-3,0 m	kg					2.650	1.700	4.150	2.650			
	3,0 m	7,5 m	kg	*1.400	*1.400			*2.050	*2.050	*2.850	*2.850			
		6,0 m	kg	*1.200	*1.200			*2.800	2.150	*2.700	*2.700			
		4,5 m	kg	*1.100	1.050	2.000	1.300	3.050	2.100	*2.950	*2.950			
		3,0 m	kg	*1.100	950	1.950	1.250	2.950	1.950	4.800	3.250			
		1,5 m	kg	*1.150	900	1.900	1.200	2.800	1.800	4.450	2.900			
		0,0 m	kg	*1.300	900	1.800	1.150	2.650	1.700	4.200	2.700	*4.250	*4.250	
		-1,5 m	kg	*1.550	1.000	1.800	1.100	2.550	1.650	4.050	2.550	*6.250	4.950	
		-3,0 m	kg	2.000	1.250			2.600	1.650	4.050	2.600	8.250	4.950	

	2,1 m	7,5 m	kg	*2.300	*2.300				*3.350	*3.350				
		6,0 m	kg	*1.500	*1.500			*3.150	2.300	*4.200	3.900			
		4,5 m	kg	*1.800	1.600			*4.550	2.300	*5.100	3.750	*5.000	*5.000	
		3,0 m	kg	*1.800	1.400	*2.400	1.450	*5.300	2.200	*6.900	3.500			
		1,5 m	kg	*1.900	1.350	*3.250	1.400	*5.700	2.050	*7.900	3.200			
		0,0 m	kg	*2.100	1.400			*5.800	2.000	*8.050	3.050			
		-1,5 m	kg	*2.600	1.550			*5.300	1.950	*7.400	3.050	*7.400	5.750	
		-3,0 m	kg							*5.700	3.100			
		2,5 m	7,5 m	kg	*1.750	*1.750					*3.350	*3.350		
			6,0 m	kg	*1.500	*1.500			*3.150	2.300	*3.450	*3.450		
			4,5 m	kg	*1.400	1.400	*1.750	1.450	*3.850	2.250	*4.000	3.750	*3.500	*3.500
			3,0 m	kg	*1.400	1.200	*3.150	1.400	*5.000	2.150	*6.450	3.500		
			1,5 m	kg	*1.500	1.150	*3.900	1.350	*5.500	2.000	*7.550	3.200		
		0,0 m	kg	*1.650	1.200	*3.850	1.300	*5.700	1.900	*8.000	3.000	*4.050	*4.050	
		-1,5 m	kg	*2.000	1.350			*5.400	1.850	*7.550	2.900	*6.900	5.500	
		-3,0 m	kg					*4.150	1.900	*6.150	2.950			
	3,0 m	7,5 m	kg	*1.400	*1.400			*2.050	*2.050	*2.850	*2.850			
		6,0 m	kg	*1.200	*1.200			*2.800	2.400	*2.700	*2.700			
		4,5 m	kg	*1.100	*1.100	*2.500	1.450	*3.150	2.300	*2.950	*2.950			
		3,0 m	kg	*1.100	1.050	*3.150	1.450	*4.150	2.200	*5.050	3.600			
		1,5 m	kg	*1.150	1.000	*3.900	1.350	*5.300	2.050	*7.200	3.250			
		0,0 m	kg	*1.300	1.050	*4.350	1.300	*5.650	1.900	*7.900	3.000	*4.250	*4.250	
		-1,5 m	kg	*1.550	1.150	*3.700	1.250	*5.550	1.850	*7.750	2.900	*6.250	5.500	
		-3,0 m	kg	*2.050	1.450			*4.700	1.850	*6.750	2.900	*9.800	5.600	

* Load is limited by hydraulic capacity rather than tipping.
 Ratings are based on SAE Standard No. J1097.
 Rated loads do not exceed 87% of hydraulic lift capacity or 75% of tipping load.

PW160-7 TWO-PIECE BOOM

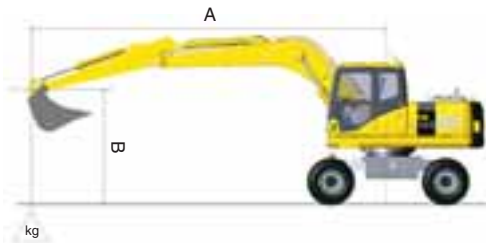

A – Reach from swing center

B – Bucket hook height















C – Lifting capacities, including bucket (495 kg), bucket linkage (90 kg) and bucket cylinder (125 kg)

 – Rating over front

 – Rating over side

 – Rating at maximum reach

When removing bucket, linkage or cylinder, lifting capacities can be increased by their respective weights.

Arm length	A	B			7,5 m		6,0 m		4,5 m		3,0 m		
													
 Front outrigger + rear blade	2,1 m	7,5 m	kg	*2.300	*2.300					*3.650	*3.650		
		6,0 m	kg	*1.900	*1.900			*3.250	*3.250	*4.200	*4.200		
		4,5 m	kg	*1.800	*1.800			*4.550	3.750	*5.100	*5.100	*5.000	*5.000
	2,5 m	3,0 m	kg	*1.800	*1.800	*2.400	*2.400	*5.300	3.650	*6.900	5.800		
		1,5 m	kg	*1.900	*1.900	*3.250	2.450	*5.700	3.500	*7.900	5.500		
		0,0 m	kg	*2.100	*2.100			*5.800	3.400	*8.050	5.350		
		-1,5 m	kg	*2.600	*2.600			*5.300	3.400	*7.400	5.300	*7.400	*7.400
		-3,0 m	kg							*5.700	5.350		
		7,5 m	kg	*1.750	*1.750					*3.350	*3.350		
	3,0 m	6,0 m	kg	*1.500	*1.500			*3.150	*3.150	*3.450	*3.450		
		4,5 m	kg	*1.400	*1.400	*1.750	*1.750	*3.850	3.750	*4.000	4.000	*3.500	*3.500
		3,0 m	kg	*1.400	*1.400	*3.150	2.450	*5.000	3.600	*6.450	5.850		
		1,5 m	kg	*1.500	*1.500	*3.900	2.400	*5.500	3.450	*7.550	5.500		
		0,0 m	kg	*1.650	*1.300	*3.850	2.350	*5.700	3.350	*8.000	5.250	*4.050	*4.050
		-1,5 m	kg	*2.000	*2.000			*5.400	3.300	*7.550	5.200	*6.900	*6.900
-3,0 m		kg					*4.150	3.350	*6.150	5.250			
7,5 m		kg	*1.400	*1.400			*2.050	*2.050	*2.850	*2.850			
6,0 m		kg	*1.200	*1.200			*2.800	*2.800	*2.700	*2.700			
 Outrigger front + rear	2,1 m	4,5 m	kg	*1.100	*1.100	*2.500	*2.500	*3.150	*3.150	*2.950	*2.950		
		3,0 m	kg	*1.100	*1.100	*3.150	2.500	*4.150	3.650	*5.050	*5.050		
		1,5 m	kg	*1.150	*1.150	*3.900	2.400	*5.300	3.500	*7.200	5.550		
	2,5 m	0,0 m	kg	*1.300	*1.300	*4.350	2.350	*5.650	3.350	*7.900	5.300	*4.250	*4.250
		-1,5 m	kg	*1.550	*1.550	*3.700	2.300	*5.550	3.300	*7.750	5.150	*6.250	*6.250
		-3,0 m	kg	*2.050	*2.050			*4.700	3.300	*6.750	5.200	*9.800	*9.800
		7,5 m	kg	*1.400	*1.400			*2.050	*2.050	*2.850	*2.850		
		6,0 m	kg	*1.200	*1.200			*2.800	*2.800	*2.700	*2.700		
		4,5 m	kg	*1.100	*1.100	*2.500	*2.500	*3.150	*3.150	*2.950	*2.950		
	3,0 m	3,0 m	kg	*1.100	*1.100	*3.150	3.000	*4.150	*4.150	*5.050	*5.050		
		1,5 m	kg	*1.150	*1.150	*3.900	2.900	*5.300	4.250	*7.200	6.800		
		0,0 m	kg	*1.300	*1.300	*4.350	2.850	5.650	4.100	*7.900	6.500	*4.250	*4.250
		-1,5 m	kg	*1.550	*1.550	*3.700	2.800	*5.550	4.000	*7.750	6.400	*6.250	*6.250
		-3,0 m	kg	*2.050	*2.050			*4.700	4.000	*6.750	6.400	*9.800	*9.800

* Load is limited by hydraulic capacity rather than tipping.
Ratings are based on SAE Standard No. J1097.
Rated loads do not exceed 87% of hydraulic lift capacity or 75% of tipping load.

HYDRAULIC WHEELED EXCAVATOR



STANDARD EQUIPMENT

- | | | | |
|--|---|--|--|
| <ul style="list-style-type: none"> • Komatsu SAA4D102E-2 90 kW direct injection emissionised Stage II intercooled turbocharged engine • Double element type air cleaner with dust indicator and auto-dust evacuator • Suction type cooling fan • Automatic fuel line de-aeration • Engine key stop • Engine ignition can be password secured on request • Engine overheat prevention system • Auto-deceleration function • Automatic engine warm-up system • Alternator 24 V/95 A • Batteries 2 × 12 V/40 Ah • Starter motor 24 V/4,5 kW • Standard counterweight • Electronic closed-centre load sensing (E-CLSS) hydraulic system (HydrauMind) | <ul style="list-style-type: none"> • Pump and engine mutual control (PEMC) system • Multi-function colour monitor with equipment management monitoring system (EMMS) • 4-working mode selection system; Active mode, economy mode, breaker mode and lifting mode • PowerMax function • Adjustable PPC wrist control levers for arm, boom, bucket and swing • One additional 2-way service valve (full flow) • Fully automatic 3-speed transmission driving through front and rear planetary axles • Orbitrol type hydraulic steering acting on front wheels • Oscilating front axle (10°) with automatic and manual cylinder locking | <ul style="list-style-type: none"> • Dual circuit hydraulic brakes with outboard wet multi-disc service brakes • Spring actuated park brake (hydraulic release) incorporated into transmission • SpaceCab™, highly pressurized and tightly sealed viscous mounted cab with tinted safety glass windows, pull-up type front window with locking device, removable lower window, front window wiper with intermittent feature, sun blind roller, magazine rack behind seat, 12 V power supply, cigarette lighter, ashtray, floor mat, machine cab handrails, suspension seat with tiltable left hand console, automatic weight adjustment, adjustable arm rests and retractable seat belt, hot and cool box | <ul style="list-style-type: none"> • Parts book and operator manual • Lockable fuel cap and covers • Fuel supply pump • Overload warning device • Boom safety valves • Climate control/Air conditioning • Radio cassette preparation • Toolkit and spare parts for first service • Single chassis tool box • Standard colour scheme and decals • Four sets of tyre and rim (twin tyre) 10.00-20 14 PR |
|--|---|--|--|

OPTIONAL EQUIPMENT

- | | | | |
|---|--|--|--|
| <ul style="list-style-type: none"> • Mono boom • Two-piece boom • 2,1 m; 2,5 m; 3,0 m arms • 2,6 m rotating arm • Parallel blade (front and/or rear) • 2 or 4 outriggers with cylinder protection • Four sets of tyre and rim (single tyre) 18.00-19.5 | <ul style="list-style-type: none"> • Nokian twin tyres 10-20 • Bandenmarkt twin tyres type grader 315/80 R 22.5 • Mechanical or hydraulic quick coupler • Komatsu buckets • Transmission guard • Clamshell grip bar • Cold weather battery 120 Ah | <ul style="list-style-type: none"> • Additional hydraulic circuits • Adjust cylinder safety valve • Arm cylinder safety valve • Heated air suspension seat • Radio-cassette • OPG Level II front guard (FOPS) • Additional RH boom lamp • Beacon preparation • Engine room lamp | <ul style="list-style-type: none"> • Additional large capacity cab roof lights (3) • Bio oil • Rain visor (not for use with OPG) • Additional chassis tool box • Customized paint |
|---|--|--|--|

KOMATSU®

Komatsu Europe International NV
 Mechelsesteenweg 586
 B-1800 VILVOORDE (BELGIUM)
 Tel. +32-2-255 24 11
 Fax +32-2-252 19 81
 www.komatsueurope.com

UESS006600 06/2004

Materials and specifications are subject to change without notice.
KOMATSU® is a trademark of Komatsu Ltd. Japan.